

EATON MODEL 11 HYDROSTATIC TRANSMISSION REPAIR INFORMATION

Table of Contents – Page 1 of 1

[PRODUCT IDENTIFICATION AND ORDERING INFORMATION](#)
[SPECIAL TOOLS TO AID IN DISASSEMBLY/REASSEMBLY](#)

[GENERAL PARTS LIST](#)

[DISASSEMBLY/REASSEMBLY](#)

[BODY/COVER--DISASSEMBLY](#)

[BODY ASSEMBLY-DISASSEMBLY](#)

[MOTOR ROTOR-DISASSEMBLY](#)

[PINTLE ASSEMBLY--REMOVAL](#)

[PINTLE ASSEMBLY--DISASSEMBLY/INSPECTION](#)

[RELIEF VALVE--REMOVAL/INSPECTION](#)

[RELIEF VALVE--INSTALLATION](#)

[DAMPENING PISTON--REMOVAL](#)

[DAMPENING PISTON--INSTALLATION](#)

[CHECK VALVE--REMOVAL](#)

[CHECK VALVE--INSTALLATION](#)

[ACCELERATION VALVES--REMOVAL](#)

[ACCELERATION VALVES--INSTALLATION](#)

[PUMP ROTOR ASSEMBLY-REMOVAL/INSPECTION](#)

[CAM RING--DISASSEMBLY/INSPECTION](#)

[CHARGE PUMP WITH BUSHING--DISASSEMBLY/INSPECTION](#)

[CHARGE PUMP WITH BALL BEARING--DISASSEMBLY/INSPECTION](#)

[COVER ASSEMBLY--DISASSEMBLY/INSPECTION](#)

[COVER ASSEMBLY--REASSEMBLY](#)

[PUMP PLATE/PORT PLATE--INSTALLATION](#)

[CHARGE PUMP WITH BUSHING---INSTALLATION](#)

[CHARGE PUMP WITH BALL BEARING--INSTALLATION](#)

[CAM RING--INSTALLATION](#)

[PUMP ROTOR ASSEMBLY--INSTALLATION](#)

[PINTLE ASSEMBLY--INSTALLATION](#)

[MOTOR ROTOR ASSEMBLY--INSTALLATION](#)

[BODY ASSEMBLY--REASSEMBLY](#)

[BODY/COVER--REASSEMBLY](#)

[START-UP PROCEDURE](#)

[TROUBLE SHOOTING INSTRUCTIONS](#)

[FLUID RECOMMENDATIONS](#)

**Eaton
Hydraulics
Division**

Repair Information

Model 11 Eaton Hydrostatic Transmissions

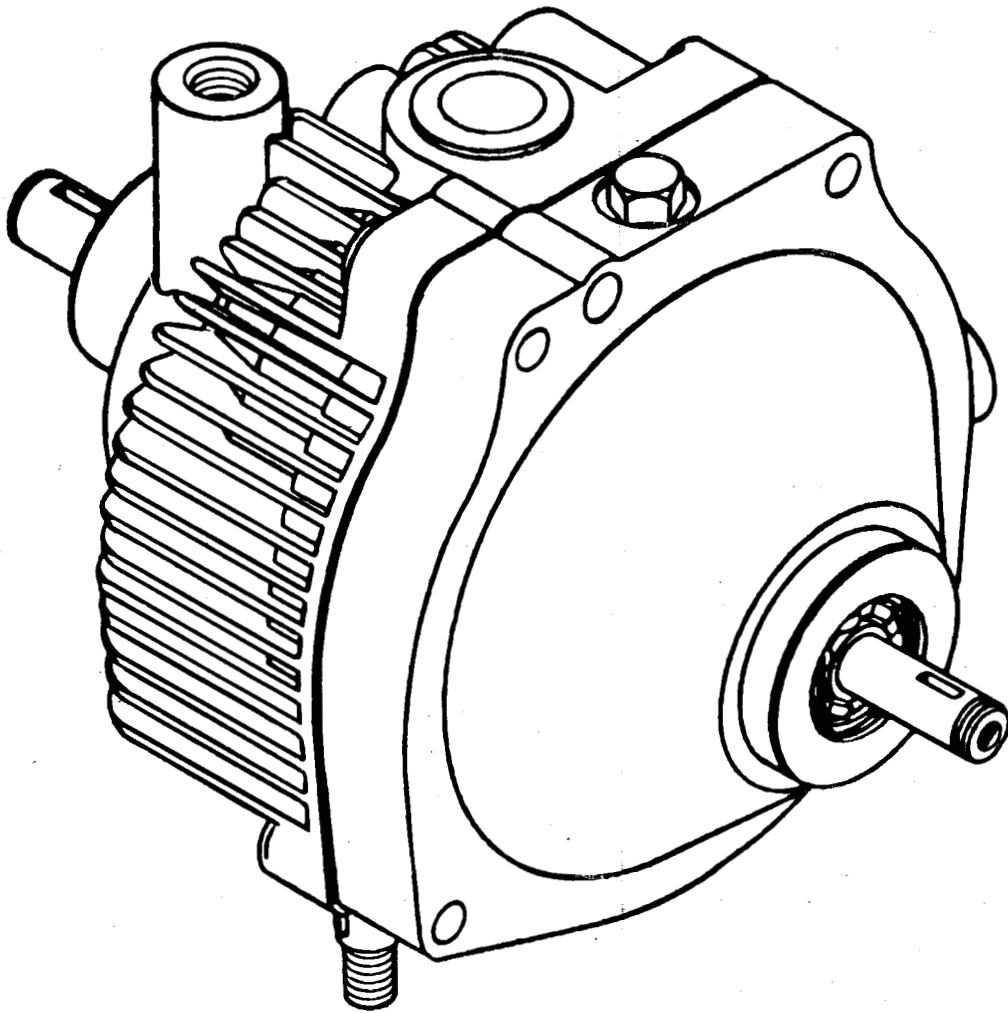

EAT•N

Contents

Product Identification and Ordering Information	5
Exploded View	6
Part Description	7
Disassembly— Reassembly Procedures	8-21
Acceleration Valves —Removal	11
Installation	11
Body Assembly —Disassembly	8
Reassembly	21
Body/Cover —Disassembly	8
Reassembly	21
Cam Ring —Disassembly/Inspection	12
Installation	19
Charge Pump with Bushing —Disassembly/Inspection	12-13
Installation	17
Charge Pump with Ball Bearing —Disassembly/Inspection	13-14
Installation	18
Check Valves —Removal	10
Installation	11
Cover Assembly	
(Input Shaft, Bushing, Oil Seal,	
Cover, Control Shaft) Disassembly/Inspection	14-15
Reassembly	15-16
Dampening Pistons —Removal	10
Installation	10
Motor Rotor Assembly —Disassembly	8-9
Installation	20
Pintle Assembly —Removal	9
Disassembly/Inspection	9-10
Installation	20
Pump Rotor Assembly —Removal/Inspection	12
Installation	20
Pump Plate/Port Plate —Installation	16
Relief Valves —Removal/Inspection	10
Installation	10
Start/up Procedures	21
Trouble Shooting	22-23
Fluid Recommendations	24

Product Identification and Ordering Information

Refer to specific listing covering your Eaton transmission. Parts listings are available from the Hydraulics Division, Minneapolis Plant.

When ordering parts, please include the following:

Model Number

Date Code

Part Number

Part Name

Quantity of Parts

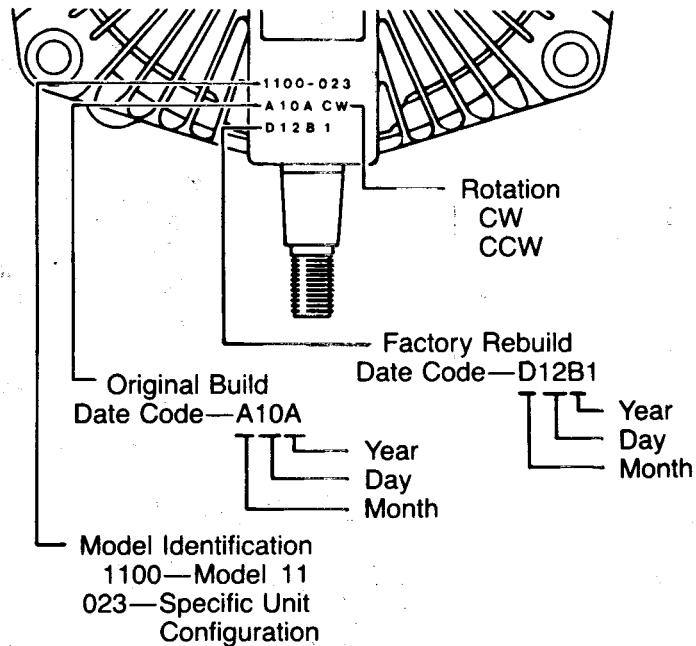

Special tools to aid in Disassembly/Reassembly

2" x 6" x 10" wooden block with $\frac{3}{4}$ " dia. hole in the center.

2 large, wide rubber bands.

$\frac{5}{16}$ -18 tap.

$\frac{3}{16}$ " dia. rod — 10"-12" long.

Two jaw bearing puller, modified slightly if necessary to fit notches in charge pump with ball bearing.

Light petroleum jelly (such as Vaseline).

Steel bar stock or piece of wood — 2" dia. x $2\frac{1}{2}$ " long.

Charge Pump with Bushing

Charge Pump with Ball Bearing

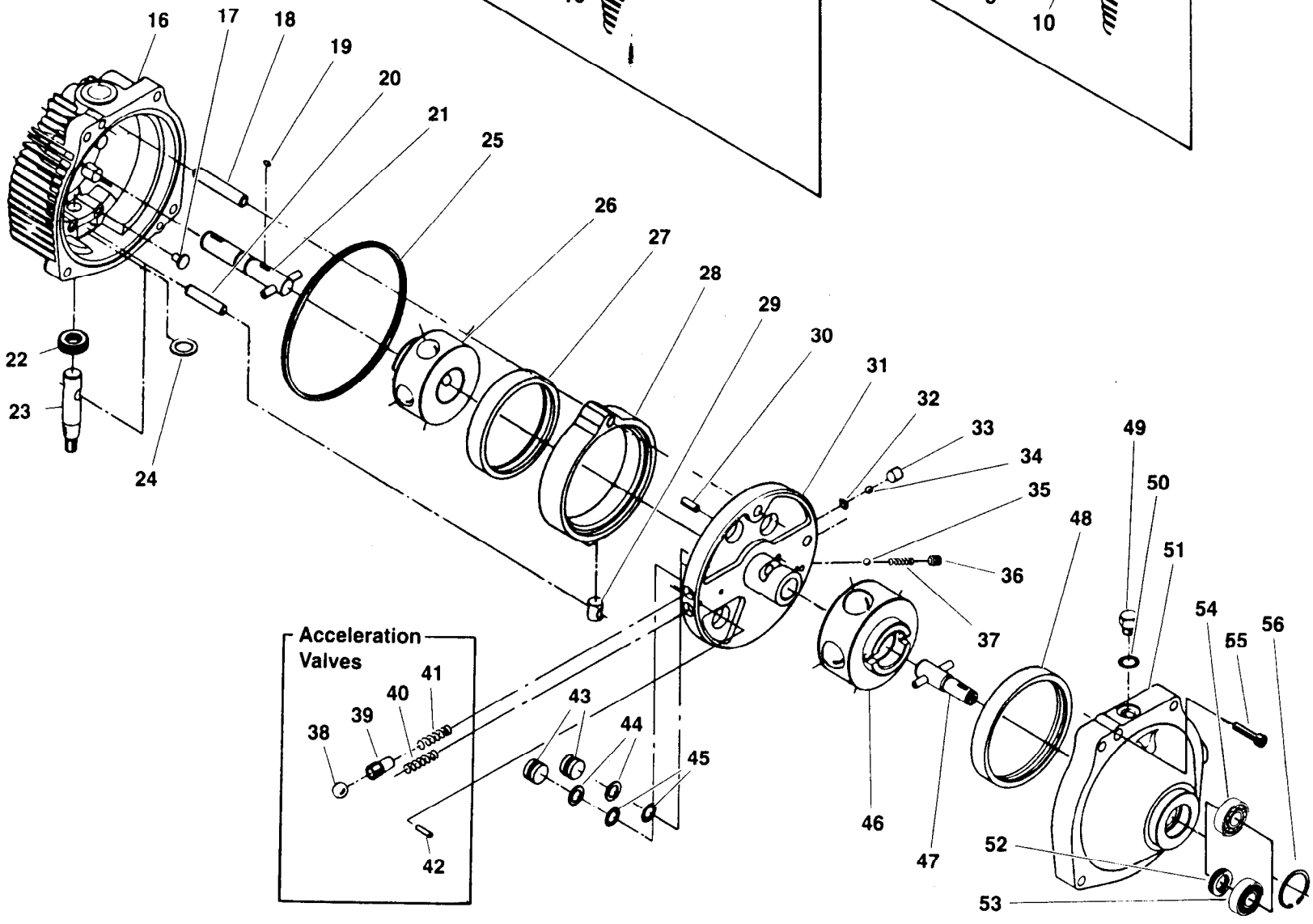
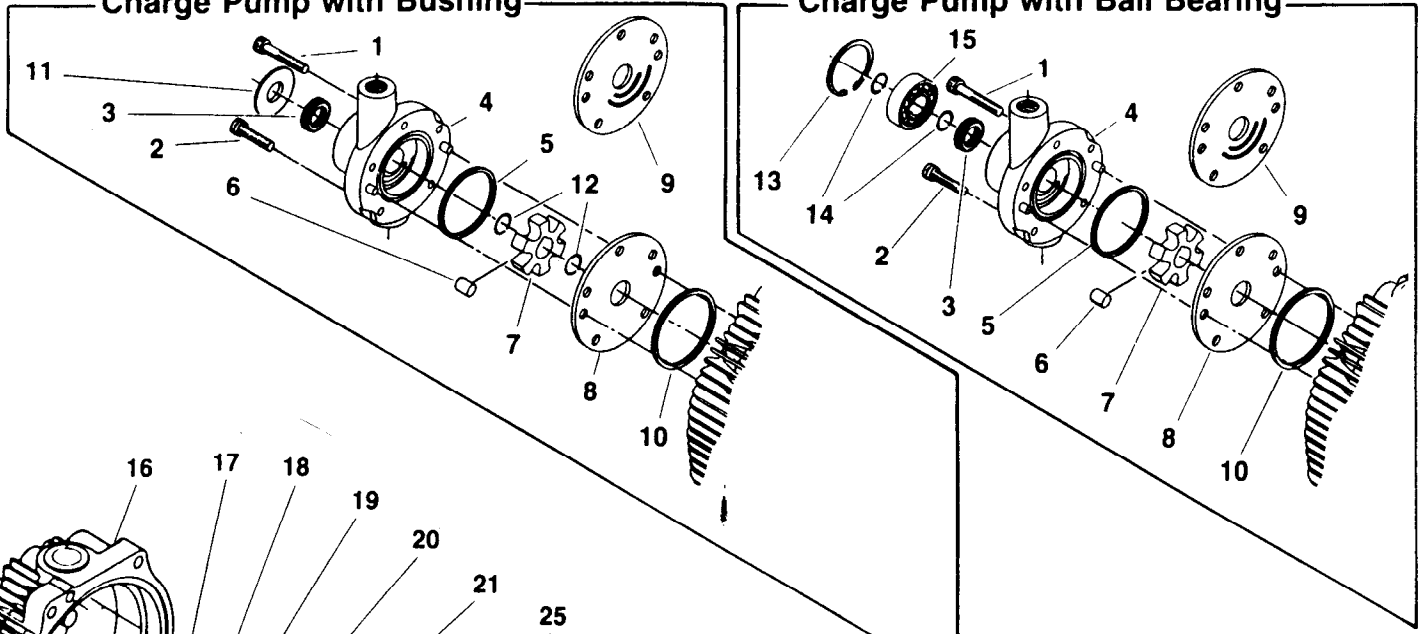

General Parts List

Item No.	Description	Item No.	Description
1	Cap Screw, Socket Head	29	Cam Ring Insert
2	Cap Screw, Socket Head	30	Coil Pin ($\frac{5}{16}$ Dia. x $\frac{3}{4}$ Lg.)
3	Oil Seal	31	Pintle
4	Charge Pump Body	32	Retaining Ring
5	Seal Ring, Square Cut	33	Check Valve Body
6	Roll	34	Check Valve Ball ($\frac{5}{16}$ Dia.)
7	Carrier	35	Check Valve Ball ($\frac{7}{16}$ Dia.)
8	Pump Plate	36	Relief Valve Plug
9	Port Plate	37	Relief Valve Spring
10	Seal Ring, Square Cut	38	Acceleration Valve Ball
11	Shield	39	Acceleration Valve Body
12	Snap Ring	40	Acceleration Valve Spring (lower)
13	Retaining Ring	41	Acceleration Valve Spring (upper)
14	Snap Ring	42	Dowel Pin
15	Bearing (Input)	43	Dampening Piston
16	Cover	44	Back-up Ring
17	Button	45	O-ring
18	Dowel, Pivot Pin	46	Motor Rotor and Ball Assembly
19	Drive Pin	47	Output Shaft
20	Dowel ($\frac{7}{16}$ Dia. x 2" Lg.)	48	Motor Race
21	Input Shaft	49	Hex Head Plug
22	Oil Seal	50	O-ring, Plug/Tube fitting
23	Control Shaft	51	Body
24	Control Shaft Washer	52	Oil Seal
25	Seal Ring, Square Cut	53	Sealed Bearing (output)
26	Pump Rotor and Ball Assembly	54	Flow Through Bearing (output)
27	Pump Race	55	Cap Screw, Socket Head
28	Cam Ring	56	Retaining Ring

This parts list is for identification of parts only. To insure the correct replacement parts for your transmission, it will be necessary to order the replacement parts by part number. For parts numbers, consult your supplier for a parts list for your specific model number.

Disassembly/Reassembly

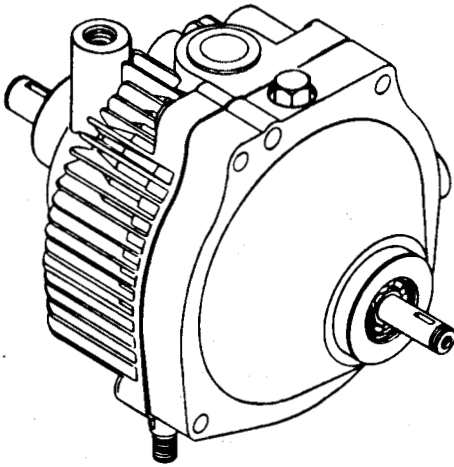

Fig. 1

Clean the transmission exterior thoroughly before repairs are begun. Use a cleaning solution that will not affect paint, gaskets, rubber seals, and plastic.

Important: When compressed air is used in cleaning, do not expose lip seals or bearing surfaces to high pressure.

Drain fluid from transmission.

Note: A 2" x 6" x 10" wooden block with a 3/4 inch hole in the center is recommended for a suitable bench fixture.

Body/Cover—Disassembly

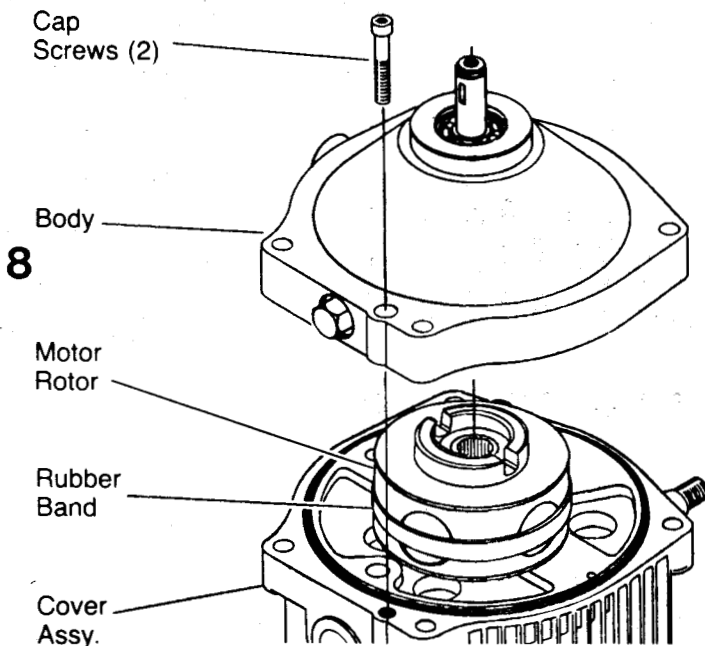

Fig. 2

1 Use a 1/4" allen wrench to remove the two 5/16" socket head cap screws.

2 Separate the body from the cover.

If the cover does not separate easily from the body because of fluid seal, tap the body and/or cover with plastic hammer to break the seal.

Important: The motor ball piston assembly must remain intact as the ball pistons are matched to the motor rotor. A large rubber band may be used to retain the ball pistons in place during handling.

Body Assembly-Disassembly

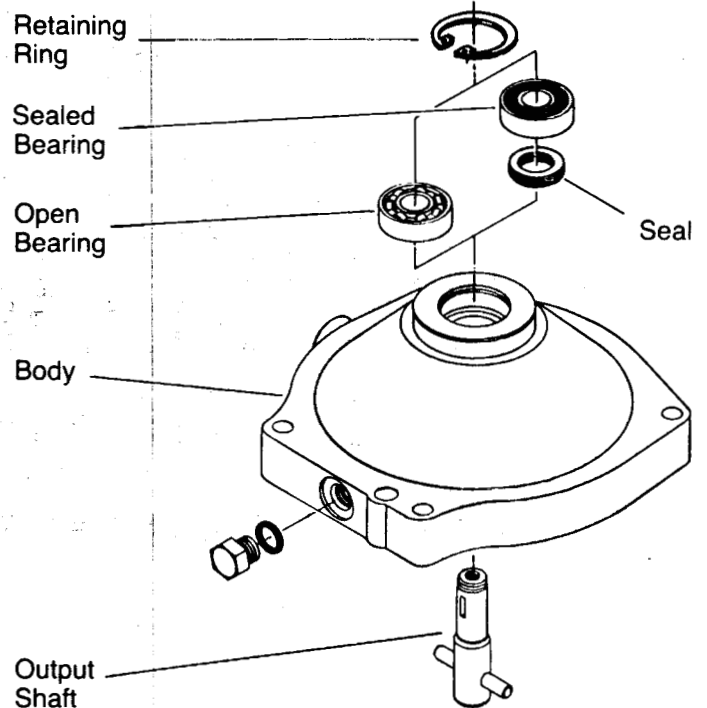

Fig. 3

3 Remove the bearing retaining ring and tap or press the output shaft inward. Drive or press the output bearing out from the motor body. Two types of output shaft bearings are used on Eaton light-duty transmissions—flow through or sealed. Sealed bearings have an oil seal located under the bearing. If your transmission has a seal, remove it by driving or pressing it out from the motor body.

Motor Rotor-Disassembly

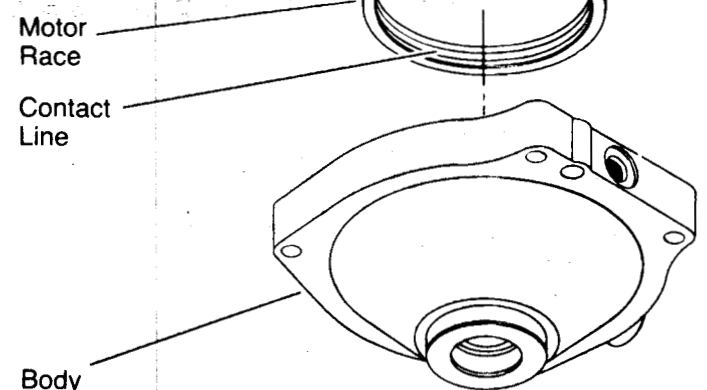

Fig. 4

4 Inspect the contact line of the motor ball pistons on the motor race located in body. This contact area must be smooth and completely free of any irregularities. If any irregularities are noted, replace the motor race.

Note: If irregularities are noted in the motor race, it is reasonable to assume that one or more ball pistons and rotor bores will also be damaged.

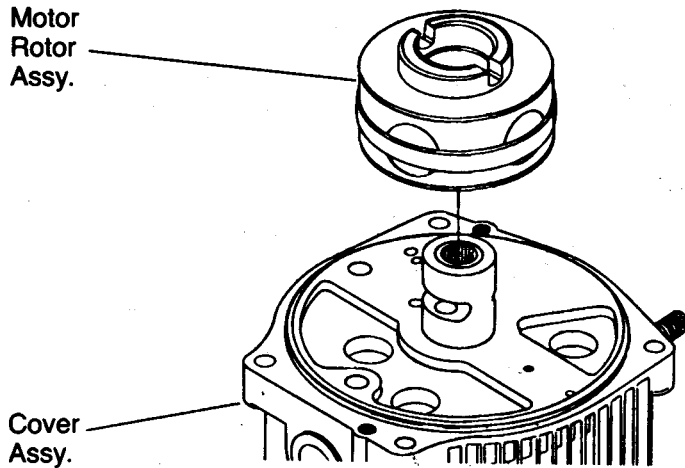

Fig. 5

5 Hold the pintle assembly in position against the cover and remove the motor rotor assembly intact.

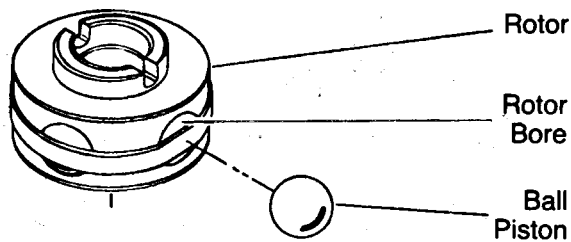

Fig. 6

6 Inspect the rotor assembly. Remove the piston balls from the rotor, one at a time, by working clockwise from the letter stamped in the face of the rotor and placing in a prepared container.

Note: Each ball must be replaced in the same bore from which it was removed. Use a suitable container for piston ball storage such as an egg carton or ice cube tray.

7 Inspect the piston balls. They must be smooth and completely free of any irregularities.

8 Inspect rotor bores, rotor bushing and pintle journals for irregularities or excessive clearance. The ball piston to rotor bore clearance is select fit electronically to .0002 to .0006 of an inch. When irregularities or excessive clearance are noted, replace the complete rotor assembly.

Install motor ball pistons in their matching bores. Hold them in place with a rubber band.

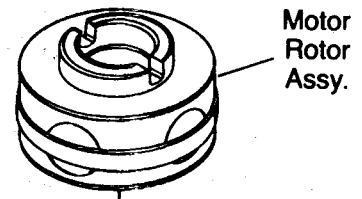

Fig. 7

Pintle Assembly—Removal

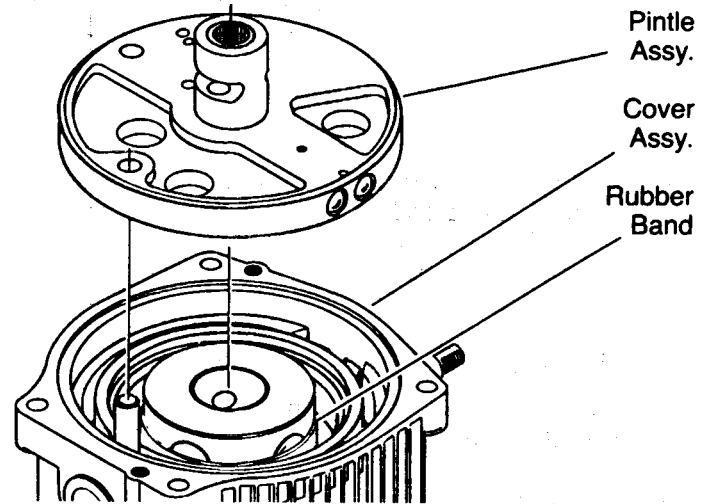

Fig. 8

9 Hold the pump assembly in the bottom position and tap lightly on the cover. Use a wood or plastic hammer so as not to damage aluminum cover. Lift the pintle assembly out.

Important: The pump ball piston assembly must remain intact as the ball pistons are matched to the pump rotor. Use a wide rubber band to retain the ball pistons in place during handling.

Pintle Assembly—Disassembly/Inspection

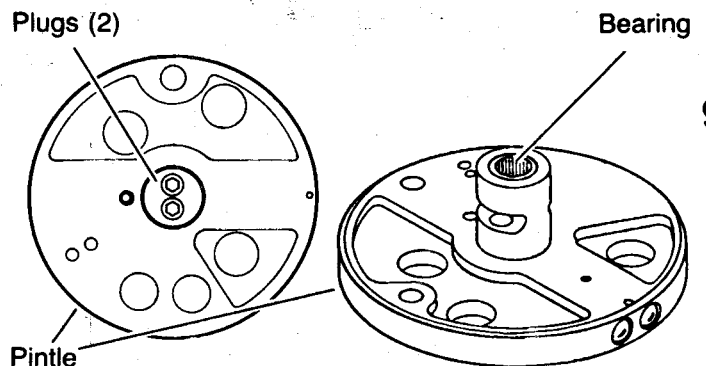

Fig. 9

10 We do not recommend complete disassembly of the pintle assembly for cleaning. Normal flushing should be all that is required. However, if complete disassembly is required, use the following procedures:

Note: Do not remove the two large plugs located on pintle journal.

Relief Valve—Removal/Inspection

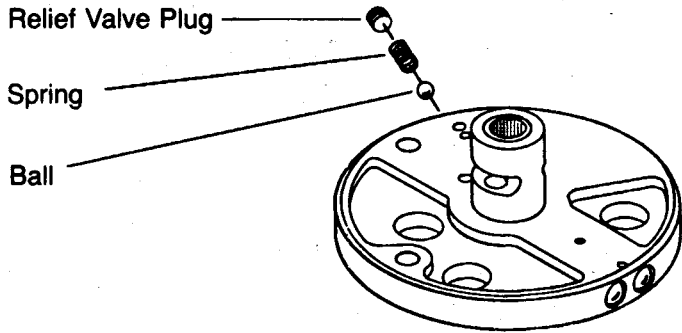

Fig. 10

11 Use a 1/4" allen wrench to remove relief valve plug. Then remove spring and ball.

12 Inspect all parts for irregularities. Replace any defective part.

Relief Valve—Installation

13 Install ball, spring and plug in pintle. Screw plug in to just below surface of pintle. **Do not tighten**

Dampening Piston—Removal

Note: Remove only if surface is scored.

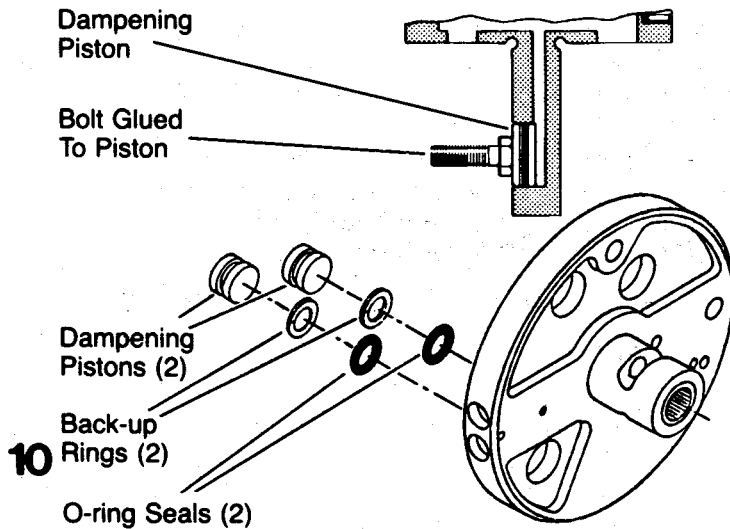

Fig. 11

14 To remove pistons, firmly tap the outside edge of pintle on a work surface. Remove back-up ring and o-ring from pistons.

Important: When dislodging dampening pistons, do not hit pintle journals or the pintle housing will be ruined.

Note: If tapping of pintle does not dislodge the pistons, use adhesive to cement a bolt or similar object to the pistons and pull them from the bore.

Dampening Piston—Installation

15 Install new back-up rings nearest to the smooth piston face and o-rings in groove on a new piston.

16 Lubricate outer surface of the pistons. Press pistons (smooth face up) in bores in pintle to the bottom position.

Check Valve—Removal

Note: Removal of check valves is not necessary if check valve balls move freely and seat properly.

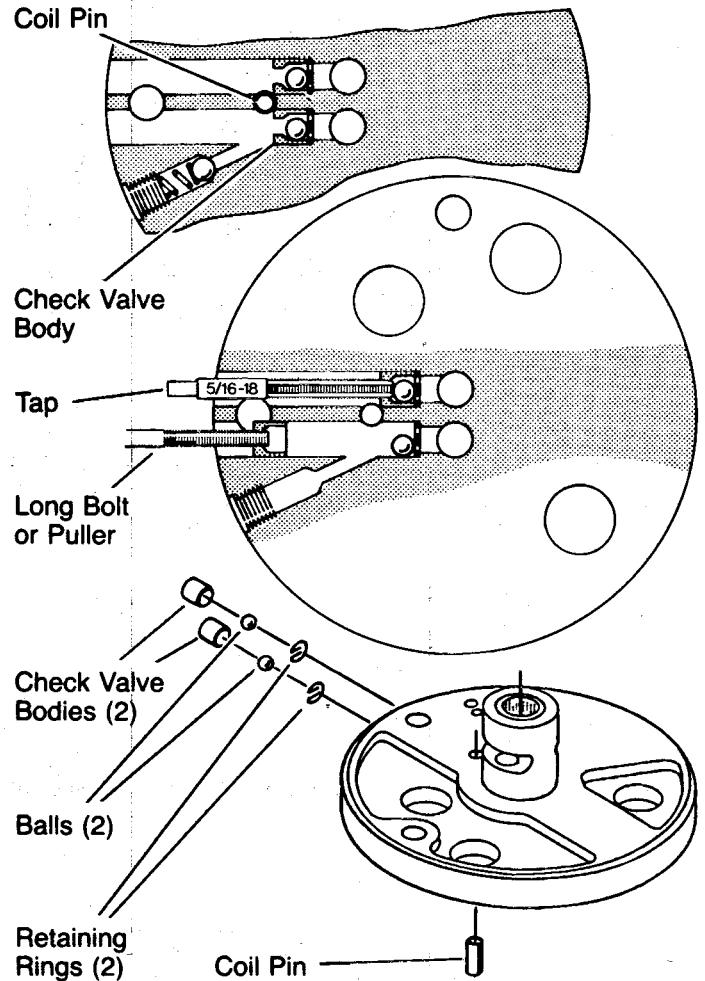

Fig. 12

17 Press or drive out the coil pin that retains the two check valve bodies. Use a four blade 5/16-18 tap to tap holes in check valve bodies. Insert a long bolt or a puller, pull the check valve bodies from the pintle housing and discard them.

18 Remove check balls and retaining ring.

Note: On units with acceleration valves—see steps 23-25 for check valve removal.

19 Inspect check valve balls and retaining rings. Replace any defective parts.

Check Valve—Installation

20 Install retaining rings and check valve balls in bores of pintle. Press *new* check valve bodies in bores. Press far enough in for coil pin clearance.

Important: To prevent dislodging of retaining rings *do not drive* check valve bodies into bores.

21 Press coil pin into pintle until flush with or slightly below surface.

Acceleration Valves—Removal

Note: Not all models have acceleration valves. If your model has them—they are located directly opposite the check valves.

See Figure 13.

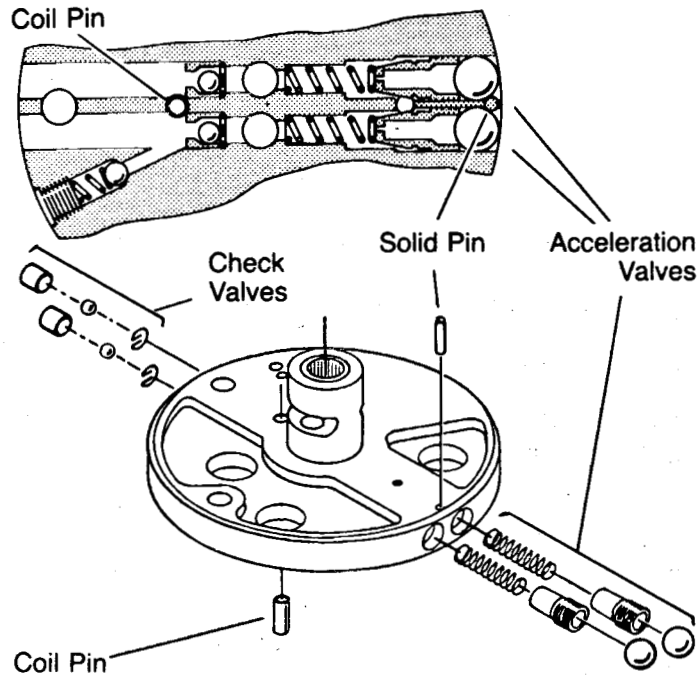

Fig. 13

22 Press solid pin from pintle housing. See Figure 13.

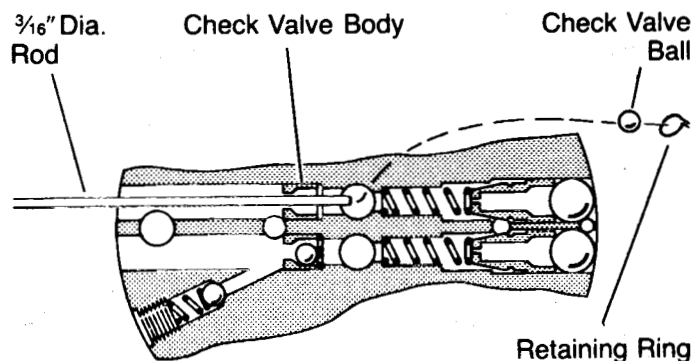

Fig. 14

23 Insert $\frac{3}{16}$ diameter rod through the check valve body. Tap the rod against the (see Fig. 14) check valve ball to dislodge the retaining rings. Repeat for the second check valve ball and ring. Shake dislodged rings and balls out the large port area of pintle journal.

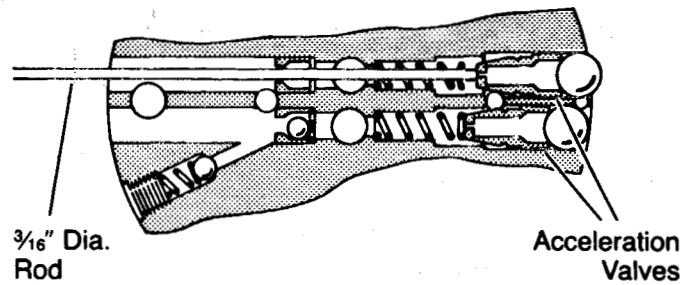

Fig. 15

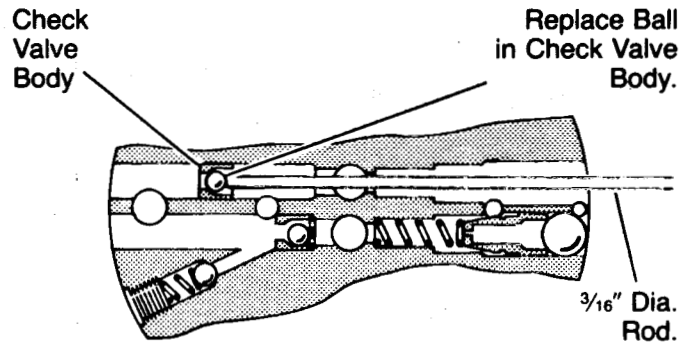

Fig. 16

24 Insert the rod through the check valve body against the acceleration valve body and drive both the valve body and ball out of the bore. Repeat method for second valve body and ball. Remove springs.

Note: Some models use different springs for forward and reverse. Be sure to identify the springs with the acceleration valves so they can be replaced in the same bore from which they were removed.

25 Press or drive coil pin from pintle housing. Replace the ball through the port into the check valve body. Place the $\frac{3}{16}$ diameter rod through the acceleration valve bore against the check valve ball and drive the check valve body and ball from the pintle housing. Repeat this method for the second check valve body.

Acceleration Valves—Installation

26 Clean all parts thoroughly. Inspect parts for defects. Replace all defective parts, including retaining rings, which were damaged when driven out of their seats.

27 Install acceleration valve springs and acceleration valves. Be sure that both acceleration valve bodies slide freely in the bores and that the orifices are clean.

28 Press the two balls against the acceleration valve bodies until the solid pin will clear. Press or drive the dowel pin in so it is flush with or slightly below the pintle surface.

29 Install new check valve retaining rings and balls in pintle bores.

30 Press new check valve bodies into bores until coil pin will clear.

Important: Use a press to install check valve bodies. Driving them into position may dislodge the retaining rings.

31 Press or drive the coil pin in to flush or slightly below pintle surface.

Pump Rotor Assembly—Removal/Inspection

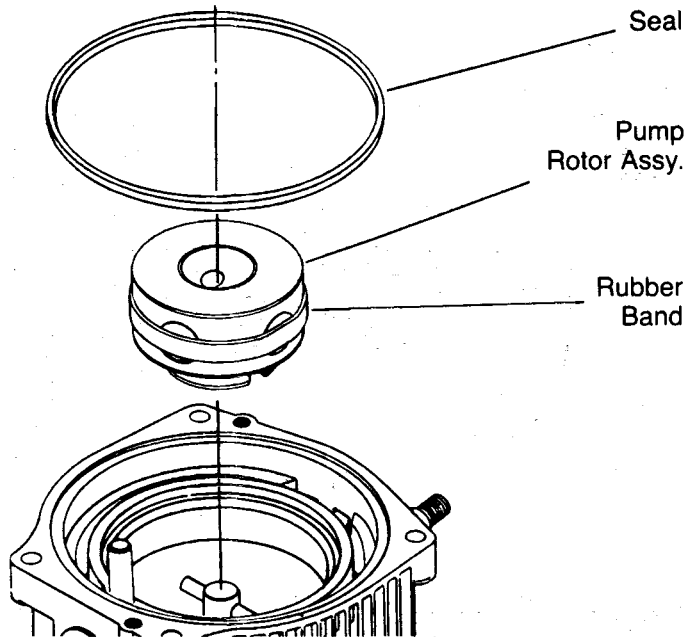

Fig. 17

32 Remove seal from cover, lift pump rotor assembly intact from the cover assembly.

Important: Use a wide rubber band to retain the ball pistons in place during handling. The pump ball piston assembly must remain intact as the ball pistons are matched to the pump rotor.

If complete disassembly, inspection and reassembly of pump rotor is necessary follow same procedures as for motor rotor—see steps 5 through 8.

12 Cam Ring—Disassembly/Inspection

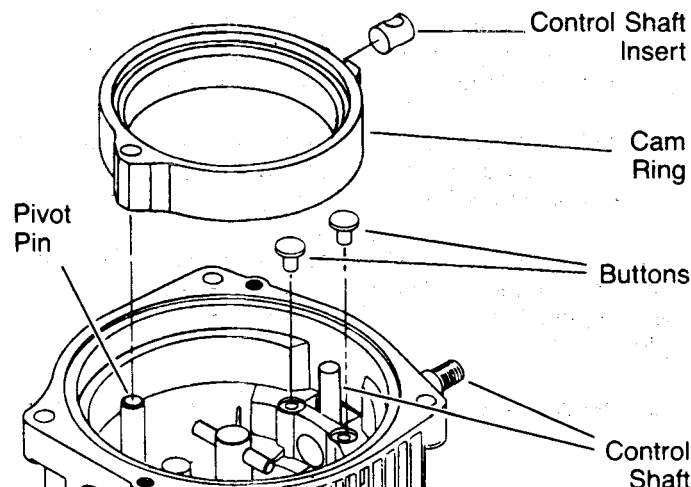

Fig. 18

33 Slide the cam ring from the pivot pin and control shaft in the cover. Then lift ring from the cover.

34 Remove the control shaft insert.

35 Inspect area where the ball pistons contact the race. This area must be smooth and completely free of irregularities. If it is not, replace the pump race.

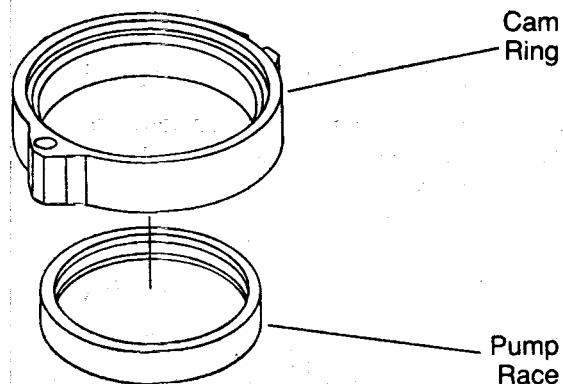

Fig. 19

Note: The pump race is press fit in the cam ring and will require a press to remove it. The cam ring and pump race are available as an assembly.

36 Remove the two buttons from cover.

Charge Pump with Bushing—Disassembly/Inspection

Note: Before removing the charge pump polish the input shaft to remove paint, burrs, nicks, etc.

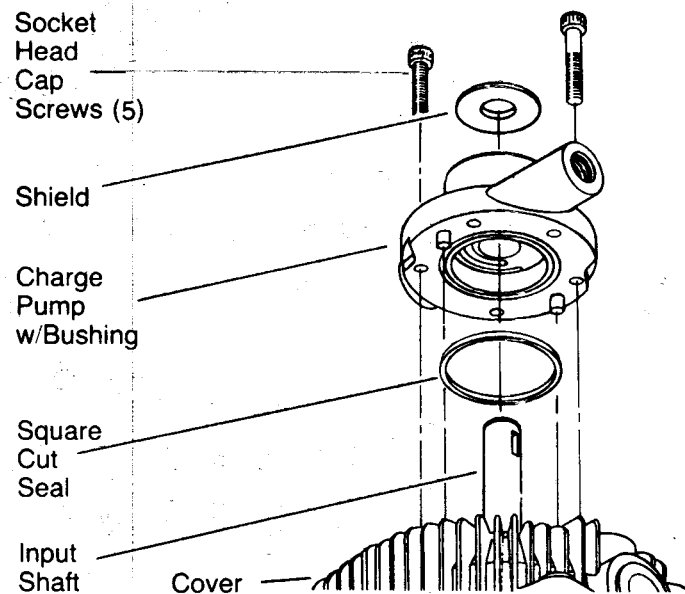

Fig. 20

37 Remove shield.

38 Use a 1/4" allen wrench to remove the 5 socket head cap screws.

39 Carefully remove the charge pump.

40 Remove the square cut seal from the charge pump housing.

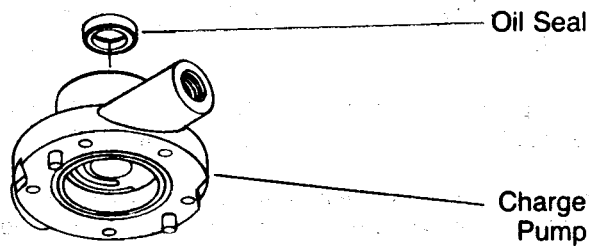

Fig. 21

41 Press or drive the oil seal from the charge pump.

Important: Be careful not to damage the input shaft bushing.

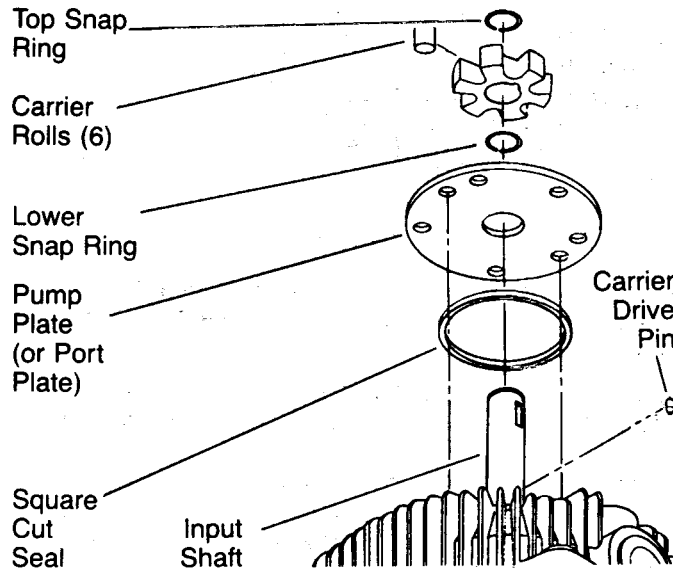

Fig. 22

42 Remove six carrier rolls.

43 Remove top snap ring from input shaft.

44 Mark top of carrier indicating which side is up.

Important: Do not mark the roll carrier in such a manner that would damage the carrier surface.

45 Remove carrier and drive pin.

46 Remove lower snap ring and pump or port plate.

47 Inspect the input shaft bushing, carrier, rolls and inner race contact areas in the charge pump. If any irregularities are found, replace the complete pump assembly.

48 Remove square cut seal from cover.

Charge Pump with Ball Bearing—Disassembly/Inspection

49 Remove pump retaining ring. See Figure 24.

50 Remove shaft retaining ring.

51 Use 1/4" allen wrench to remove five cap screws.

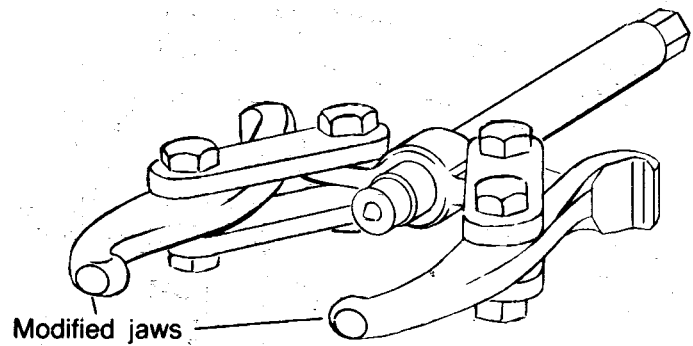

Fig. 23

52 Use a modified two jaw bearing puller, pulling against the two notches machined in the housing to remove the charge pump assembly.

Important: Do not pound on the bearing puller while removing the charge pump body. Apply a steady pull only.

Important: Do not damage the bore for the input shaft during removal of charge pump.

53 Remove the square cut seal from the pump assembly.

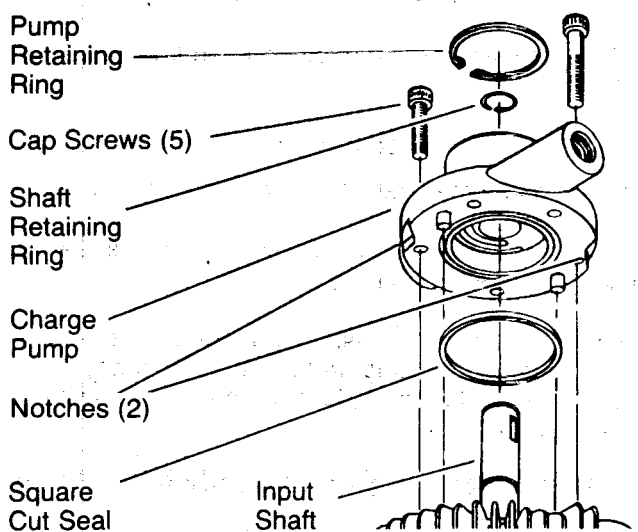

Fig. 24

54 Remove the bearing and the oil seal from the charge pump. Discard the oil seal.

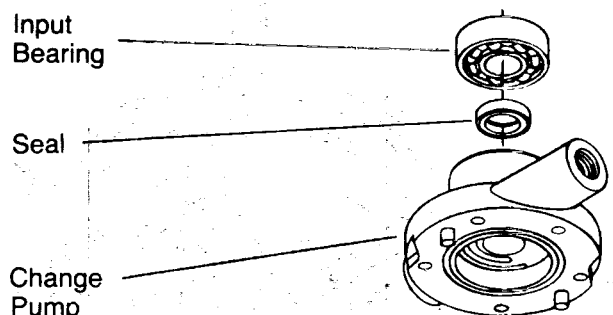

Fig. 25

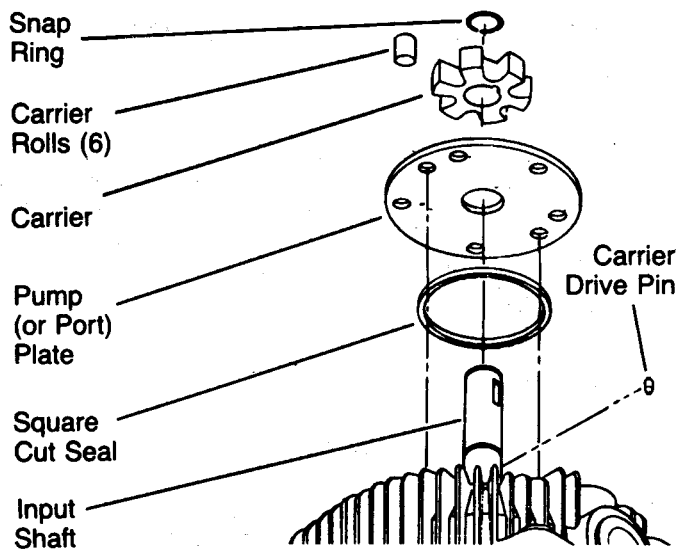

Fig. 26

55 Remove six carrier rolls.

56 Remove snap ring.

57 Mark top of carrier indicating which side is up.

Important: Do not mark the roll carrier in a way that would damage the carrier surface.

58 Remove carrier and carrier drive pin from input shaft.

59 Remove pump (or port) plate.

Remove square cut seal from cover and discard.

60 Inspect the ball bearing. If any irregularities are present, replace the bearing.

61 Inspect the carrier, rolls, inner race contact areas in the charge pump housing and pump plate. If any irregularities are found, replace the complete charge pump assembly.

Cover Assembly — Disassembly/Inspection

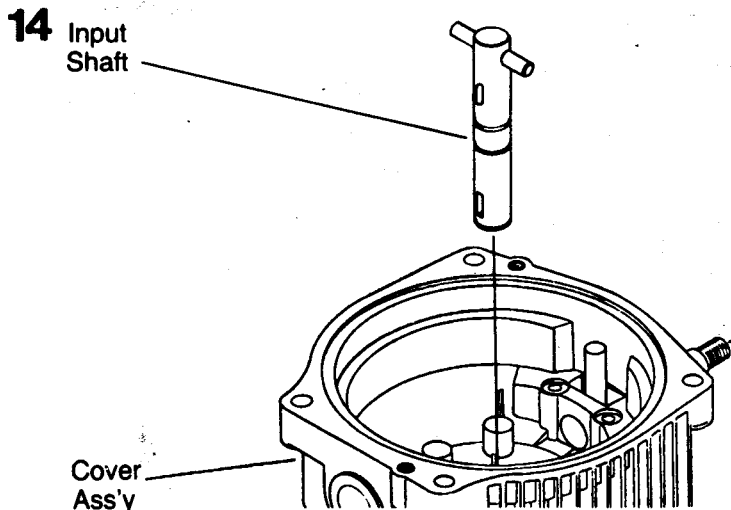

Fig. 27

62 Reposition cover assembly as shown in Figure 27. Then remove input shaft.

Important: Be careful not to damage the input shaft bushing in the cover.

63 Inspect input shaft for stripped keyways or other irregularities. If found, replace the input shaft.

64 Inspect bushing located in face of cover for broken bushing or other irregularities. If found, replace the cover.

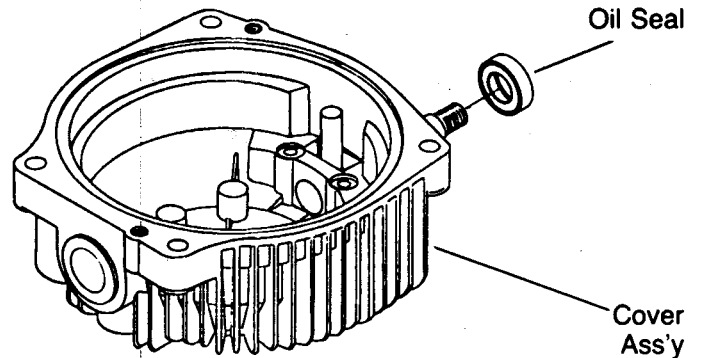

Fig. 28

65 Use a sharp, narrow edged tool to pierce the top metal part of the oil seal and remove seal from the cover.

Important: Do not scratch the control shaft or distort the seal counter bore when removing seal.

66 Inspect cover assembly, especially around the control shaft area. Replace the cover assembly if it is broken, cracked or if side clearance between control shaft and cover exceeds .006".

67 In most cases, it will not be necessary to remove the control shaft from the cover. If the dowel is loose or broken in the control shaft, remove the shaft using the following procedures.

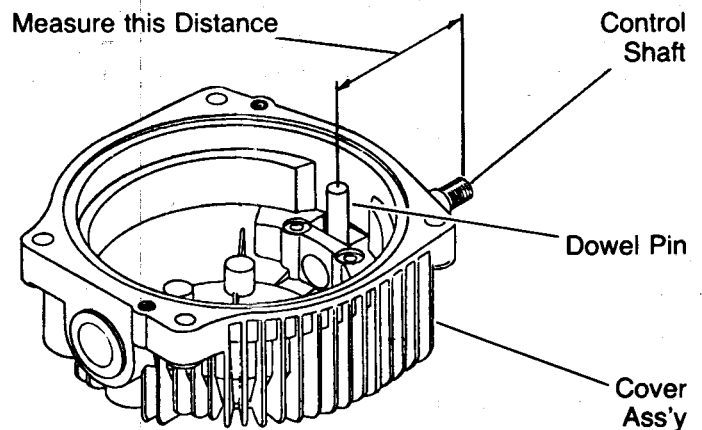

Fig. 29

68 Measure the distance between center of dowel pin and the end of the shaft as shown in Figure 29.

69 Turn cover over. Use dimension obtained in Step 68 to locate dowel pin in cover face. Drill $1\frac{1}{32}$ " diameter hole at center point of dowel pin. Drill hole exactly in line with center of shaft.

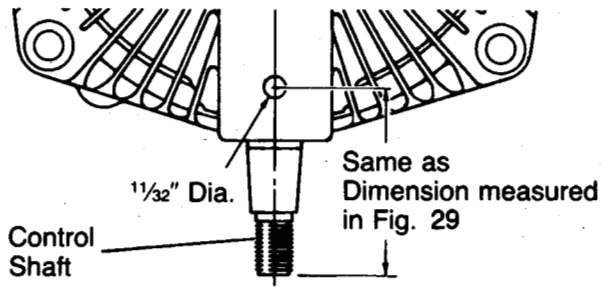

Fig. 30

70 Press damaged pin from control shaft. Remove control shaft and washer.

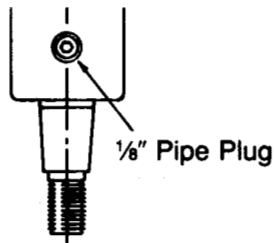

Fig. 31

71 Tap hole drilled in Step 69 with $\frac{1}{8}$ " pipe tap. Install $\frac{1}{8}$ " diameter flush type pipe plug.

Cover Assembly—Reassembly

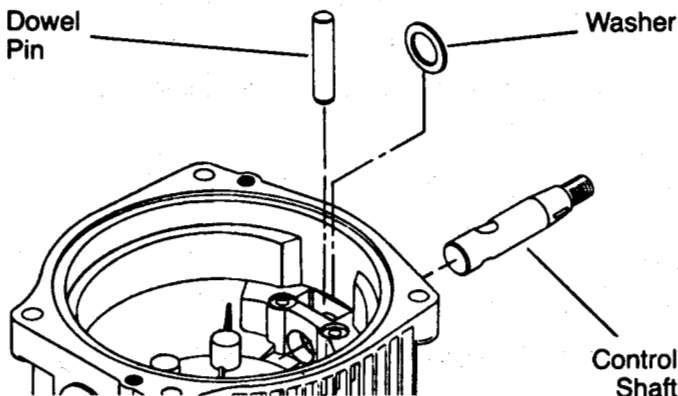

Fig. 32

72 Install new control shaft and washer in cover.

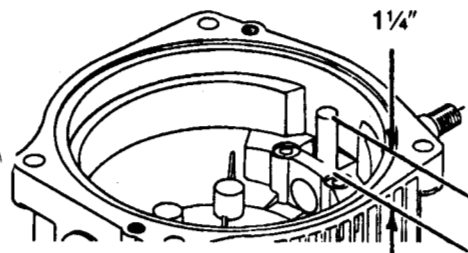

Fig. 33

73 Press new dowel pin through the shaft. Leave $\frac{1}{4}$ " of dowel extending from the shaft.

74 Lubricate I.D. of new oil seal with clean lubricant. Then press or tap seal in bore until completely seated.

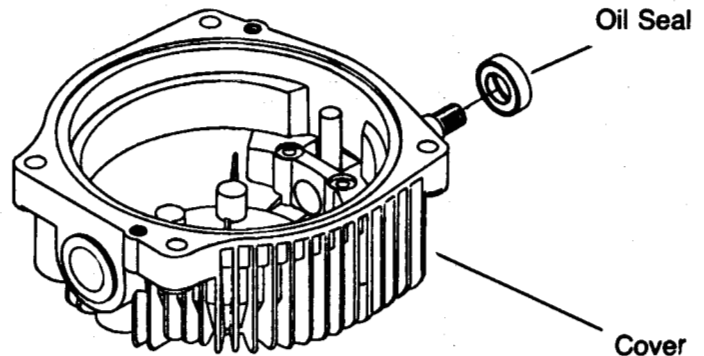

Fig. 34

Important: Be careful not to damage the inner portion of the oil seal. Excessive pressing or driving of the oil seal will damage the rubber portion of the oil seal.

75 Install input shaft in cover.

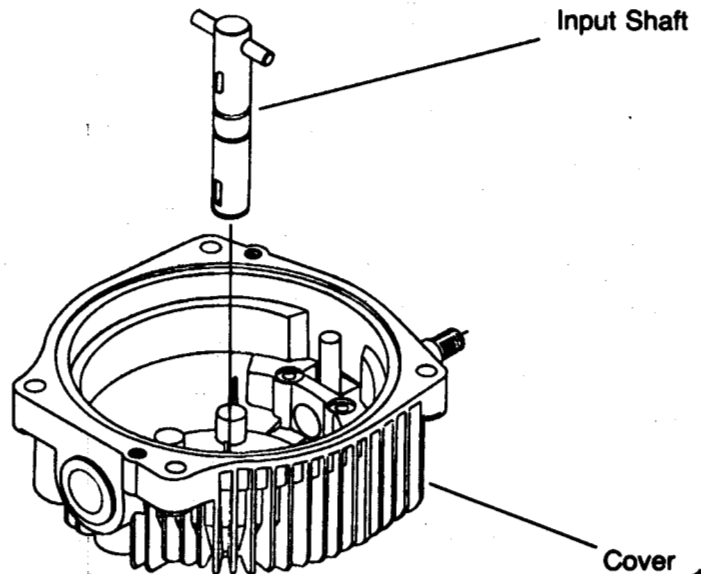

Fig. 35

76 Turn cover over. Support input shaft from underneath. Use a piece of steel bar stock or hard wood—2" in diameter by at least $2\frac{1}{2}$ " long to keep the shaft cross pin against the cover.

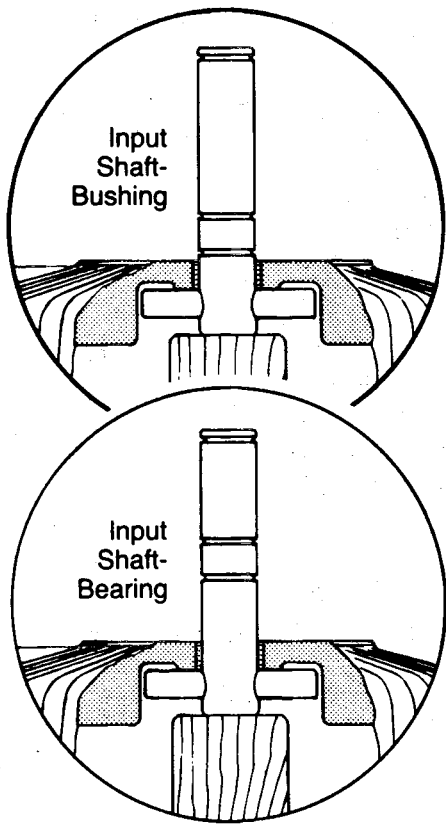

Fig. 36

77 Lightly lubricate new square cut seal and install in seal groove in cover.

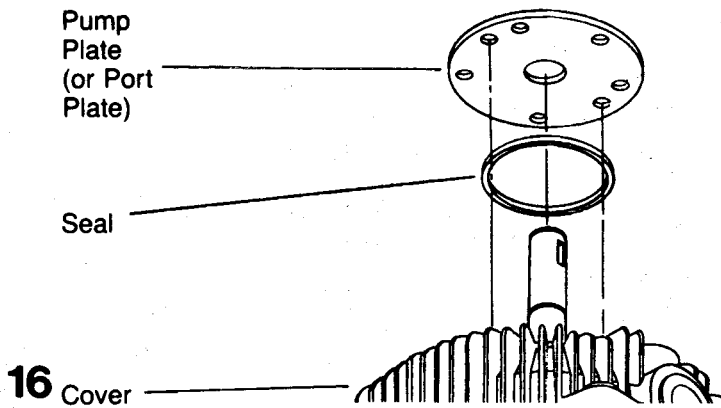

Fig. 37

Pump Plate/Port Plate—Installation

78 Install pump plate or port plate on cover. Either side of the pump plate may face the cover regardless of input rotation. However, the port plate must be installed per specific input rotation. See Figure 38.

Important: Stamping on cover indicates if charge pump rotation is clockwise or counter clockwise.

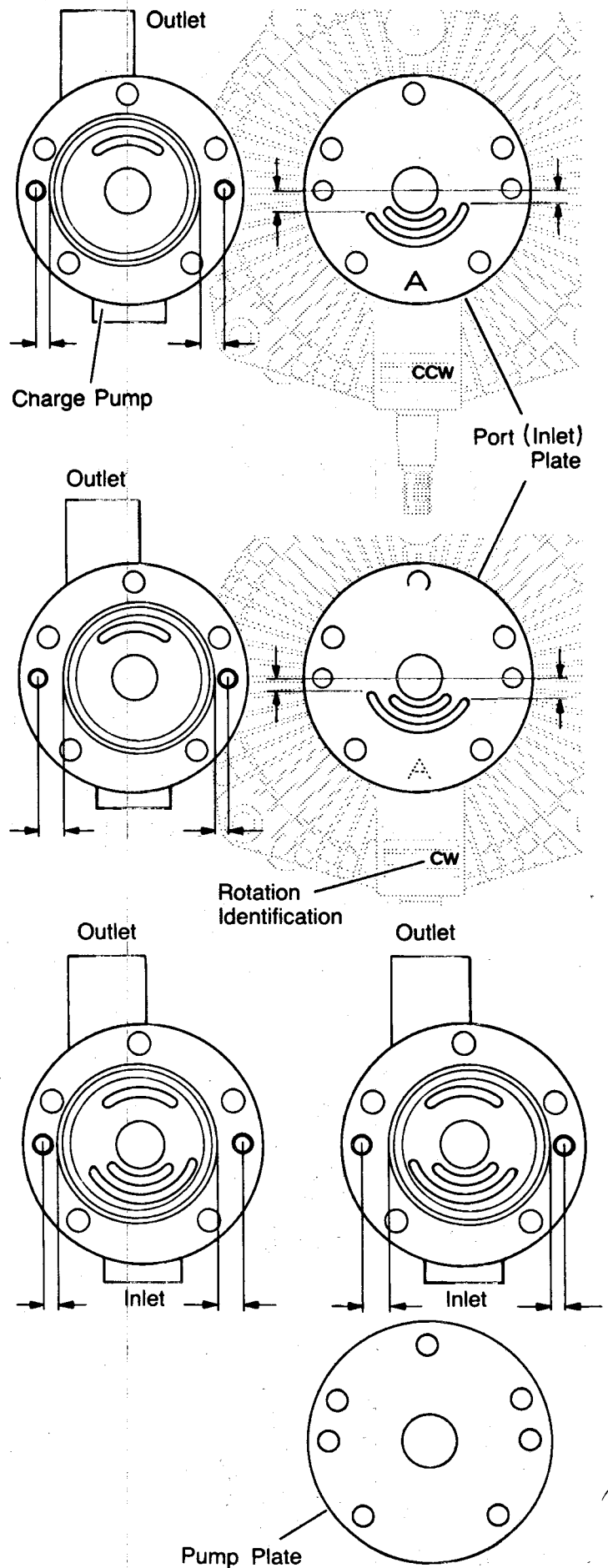

Fig. 38

79 For counter clockwise (CCW) rotation, the letter A must be up, facing the charge pump. For clockwise (CW) rotation the letter A must face down toward the cover.

Charge Pump with Bushing—Installation

For charge pumps with ball bearing, see Steps 89 through 94 for installation.

Install snap ring in lower snap ring groove (against plate) of input shaft.

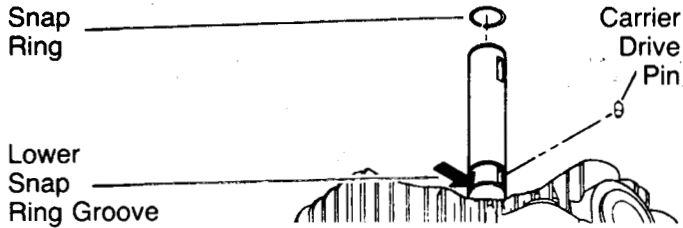

Fig. 39

80 Install carrier drive pin in keyway of input shaft. Use a small amount of petroleum jelly or equivalent to hold pin in place.

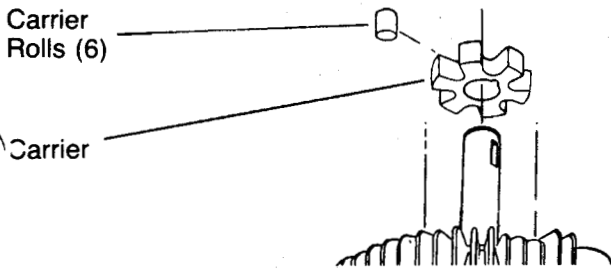

Fig. 40

81 Install carrier over input shaft with side marked "up" (see step 57). Be sure keyway in carrier fits over carrier drive pin in output shaft.

Important: For correct carrier rotation the leading edge of carrier must rotate in the same direction as the input shaft. Install as shown in Figure 41.

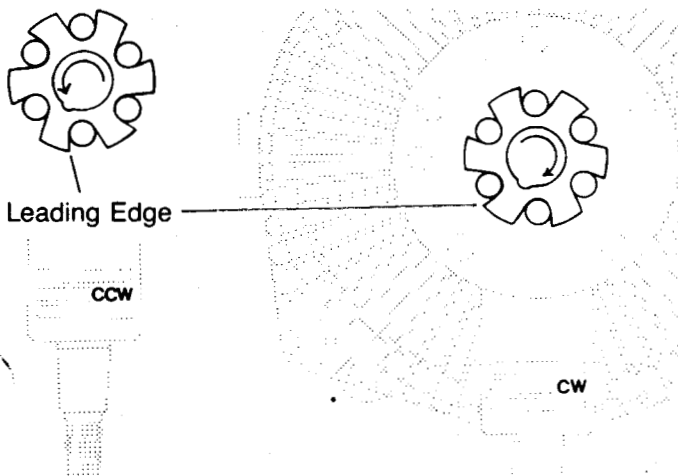

Fig. 41

82 Install snap ring in upper snap ring groove in input shaft (against carrier).

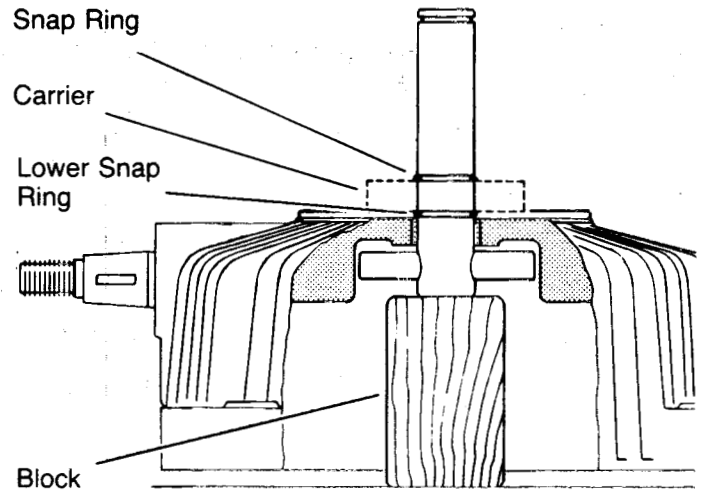

Fig. 42

83 Lightly lubricate the six carrier rolls and install them in the carrier.

84 Lubricate inner surface of new oil seal and install in charge pump housing as shown in Figure 43 with the rubber lip toward the bore. Make sure seal is completely seated.

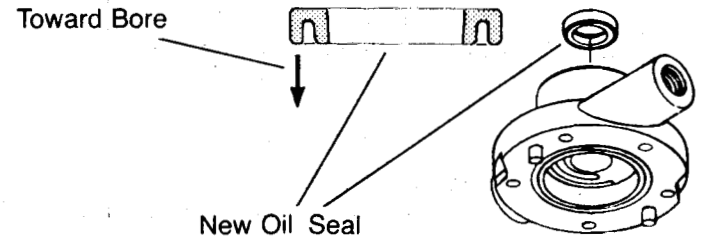

Fig. 43

Important: Excessive pressing or force on oil seal may cause damage to rubber sealing portion or may distort counterbore of housing.

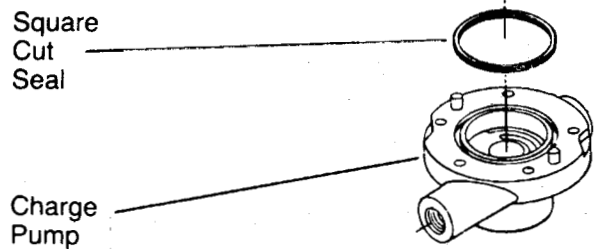

Fig. 44

85 Lightly lubricate new square cut seal with petroleum jelly and install in seal groove of pump housing.

Important: If an elbow fitting is used in the pump inlet, it must be installed before mounting charge pump.

*Charge pump with Bearing see page 18.

86 Align charge pump dowel pins with holes in cover. Then guide pump over shaft, carrier and rolls until pins engage holes.

Important: Protect oil seal lip from keyways, snap ring grooves and shaft splines.

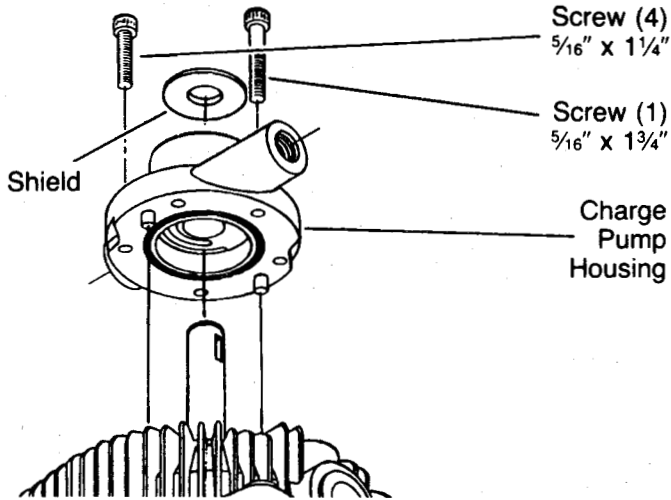

Fig. 45

87 Install 4 screws (5/16" x 1 1/4") and one screw (5/16" x 1 3/4") in pump housing. Torque to 15 foot pounds.

Important: Install 1 3/4" screw in thicker section of charge pump body. If installed and tightened in any of the other four holes, internal damage could occur.

88 Install protective shield on housing.

Important: Install protective shield so that flange is pointing away from oil seal. Shield may damage oil seal if installed improperly.

Charge Pump with Ball Bearing—Installation

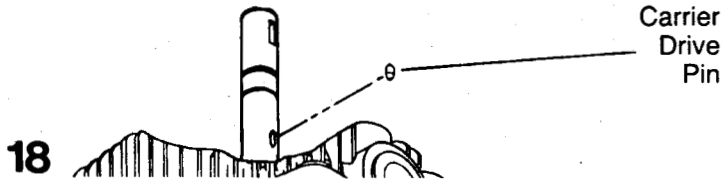

Fig. 46

89 Lubricate carrier drive pin and install in keyway of input shaft.

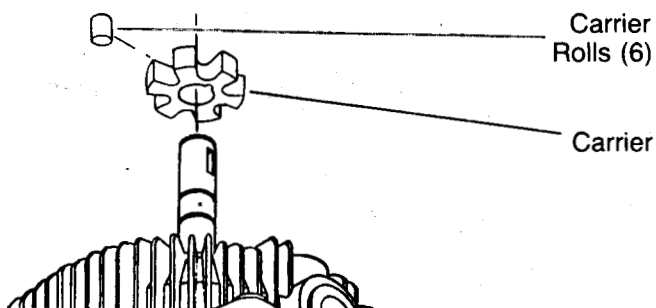

Fig. 47

90 Install carrier over input shaft with side marked "up" (see step 57). Be sure keyway in carrier fits over carrier drive pin in input shaft.

Important: For correct carrier rotation the leading edge of carrier must rotate in the same direction as the input shaft. Install as shown in Figure 48.

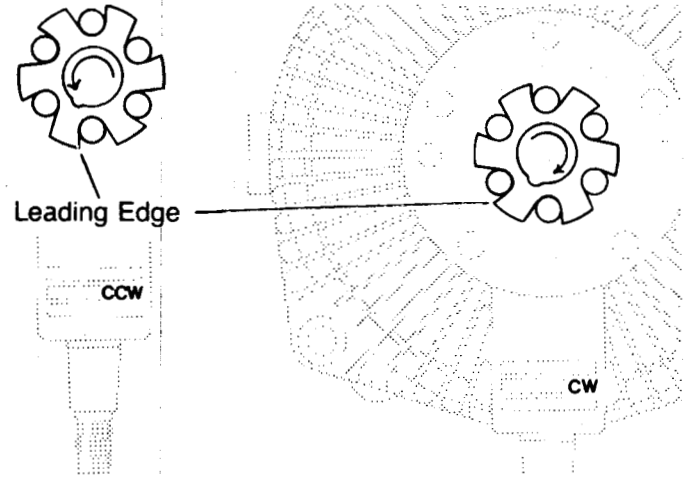

Fig. 48

91 Lightly lubricate and install the six carrier rolls in the carrier. Use a small amount of petroleum jelly or equivalent to hold the rolls in place.

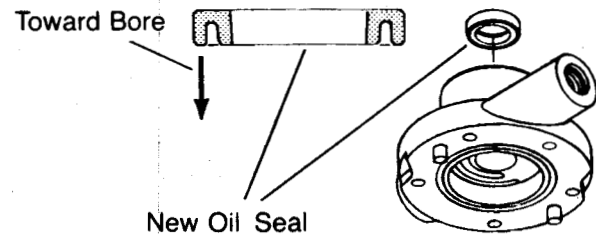

Fig. 49

92 Lubricate inner surface of new oil seal and install in charge pump housing as shown in Figure 49 with the rubber lip toward the bore. Make sure seal is completely seated.

Important: Excessive pressing or force on oil seal may cause damage to rubber sealing portion or may distort counterbore of housing.

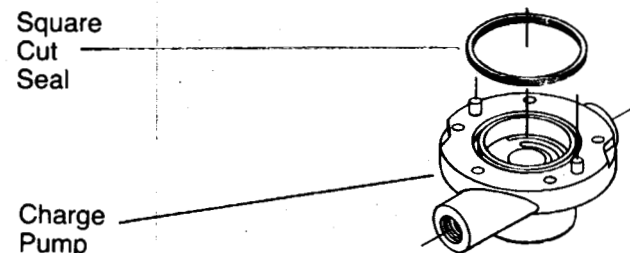

Fig. 50

93 Lightly lubricate new square cut seal and install in seal groove of pump housing.

Important: If an elbow fitting is used in the pump inlet, it must be installed before mounting charge pump.

94 Align charge pump dowel pins with holes in cover. Protect oil seal lip from keyways, snap ring grooves and shaft splines. Then guide pump over shaft, carrier and rolls until pins engage holes.

Screw (4)
5/16" x 1 1/4"

Screw (1)
5/16" x 1 3/4"

Charge
Pump
Housing

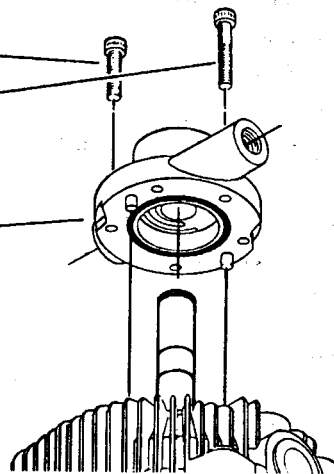

Fig. 51

95 Install 4 screws (5/16" x 1 1/4") and one screw 5/16" x 1 3/4") in pump housing. Torque to 15 foot pounds.

Important: Install 1 3/4" screw in thicker section of charge pump body. If installed and tightened in any of the other four holes, internal damage could occur.

Upper Snap Ring

Ball Bearing

Lower
Snap Ring

Block

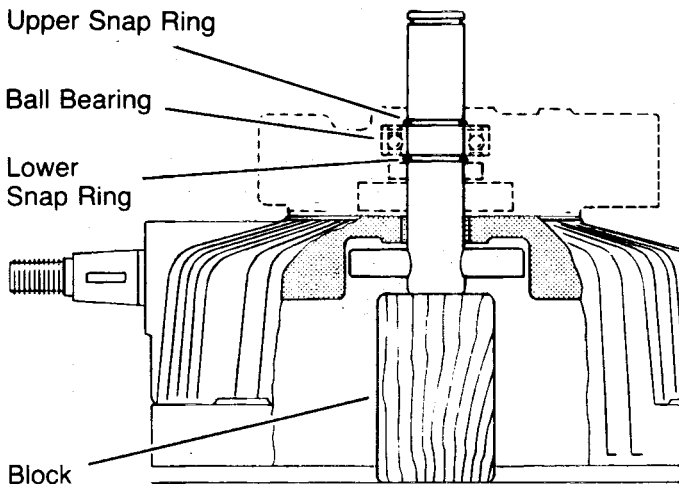

Fig. 52

96 Install snap ring in lower groove of input shaft.

97 With cover assembly separated from the body and the input shaft properly supported (see Figure 52) the input shaft bearing may be pressed into position.

Press to the bottom position in the charge pump housing against the retaining ring.

98 Install snap ring in upper groove of input shaft against inner bearing race.

99 Install large snap ring used to retain bearing in housing.

Retaining
Ring

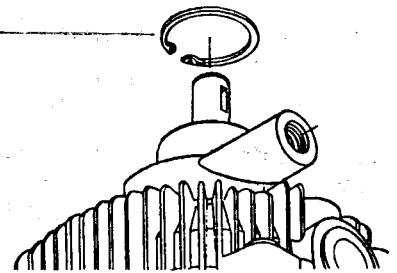

Fig. 53

Important: Input shaft should rotate freely by hand. If it does not, recheck installation.

Cam Ring—Installation

100 Install 2 buttons in the cover as shown in Figure 54.

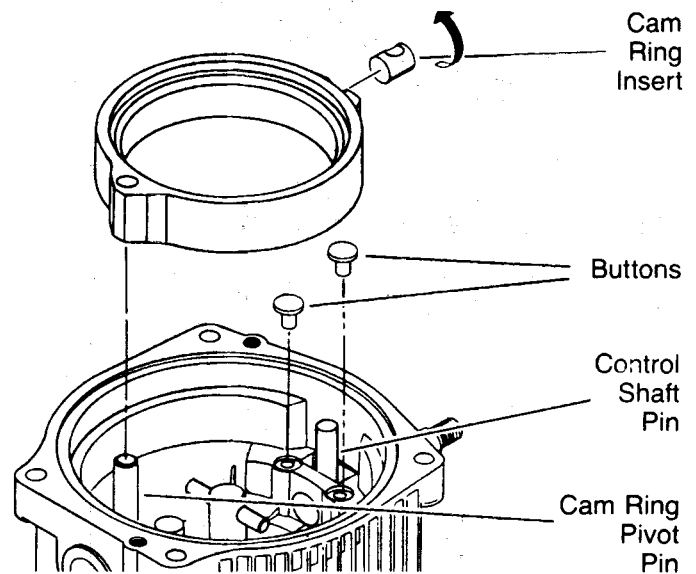

Fig. 54

101 Install the cam ring insert with the hole away from the cam ring as shown in Figure 54.

102 Align the cam ring with the control shaft pin and the cam ring pivot pin.

Install the cam ring with the flush side of the bearing race facing the cover. Press in firmly until the cam ring has bottomed in the cover assembly.

Important: Cam ring must move freely from stop to stop. If binding occurs at either stop rotate the cam ring insert 180°. Check the cam ring movement again.

Pump Rotor Assembly—Installation

103 Align the slot in the pump rotor with the input shaft cross pin. Install rotor assembly on shaft.

Important: Keep rotor assembly intact with wide rubber band. Remove rubber band after installing rotor assembly in cover assembly.

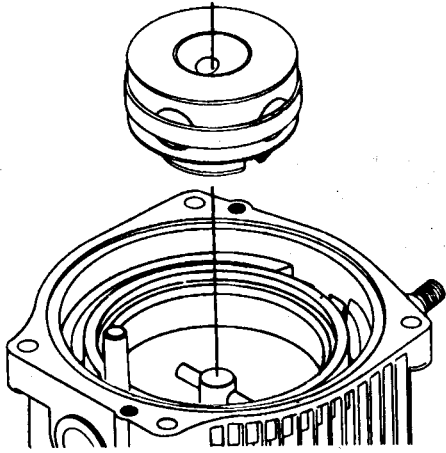

Fig. 55

Pintle Assembly—Installation

Note: To determine pintle rotation, place a small ruler or straight edge in the porting slot as shown in Figure 56.

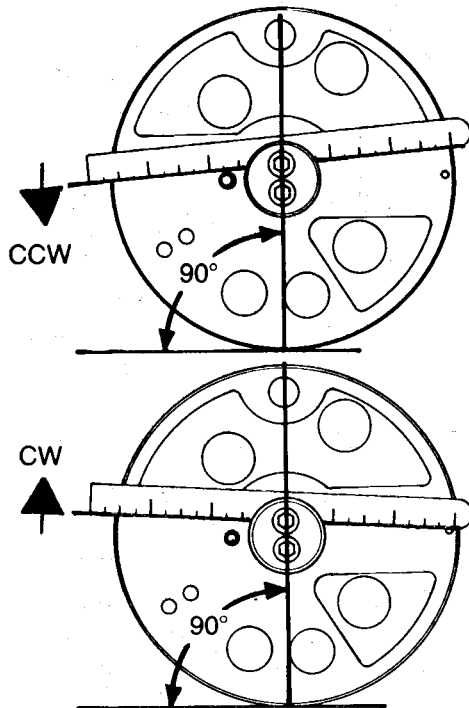

Fig. 56

104 Align dowel pin hole in pintle assembly with cam ring pivot pin and install over pump rotor assembly.

105 Lightly grease a new square cut seal and install it in the groove in the housing.

Important: Do not force pintle over rotor assembly. It is a slip fit and the pintle must turn freely by hand. If it does not, recheck the pintle installation.

Motor Rotor Assembly—Installation

106 Install the motor rotor assembly on the pintle. See Figure 57.

Important: Do not force the rotor assembly over the pintle. It is a slip fit and the rotor must rotate freely by hand.

Keep the rotor assembly intact with wide rubber band. Remove rubber band after installing rotor assembly.

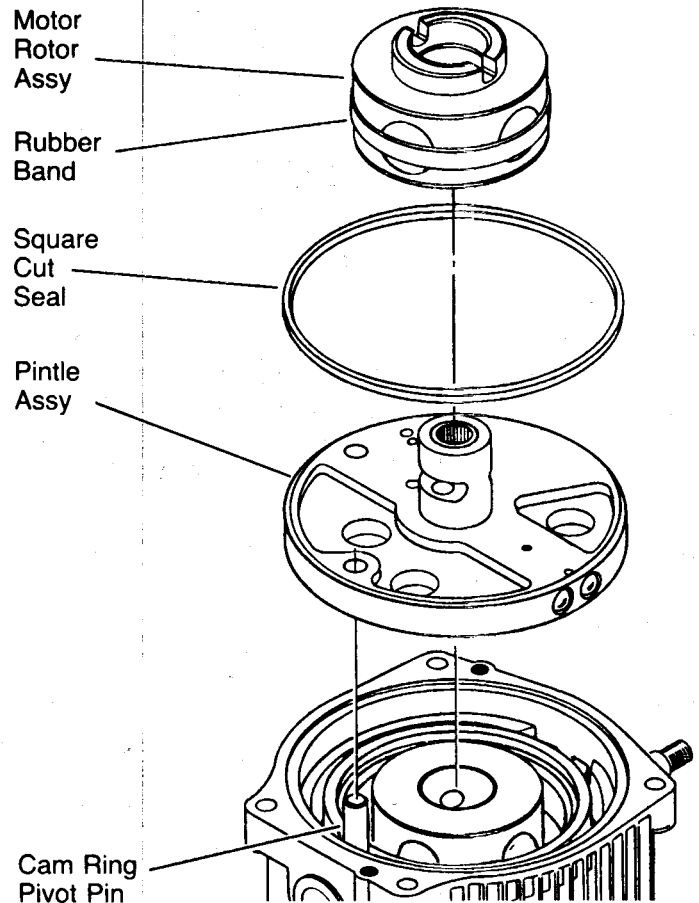

Fig. 57

Body Assembly—Reassembly

Note: Transmissions with sealed bearings incorporate an oil seal under the output bearing.

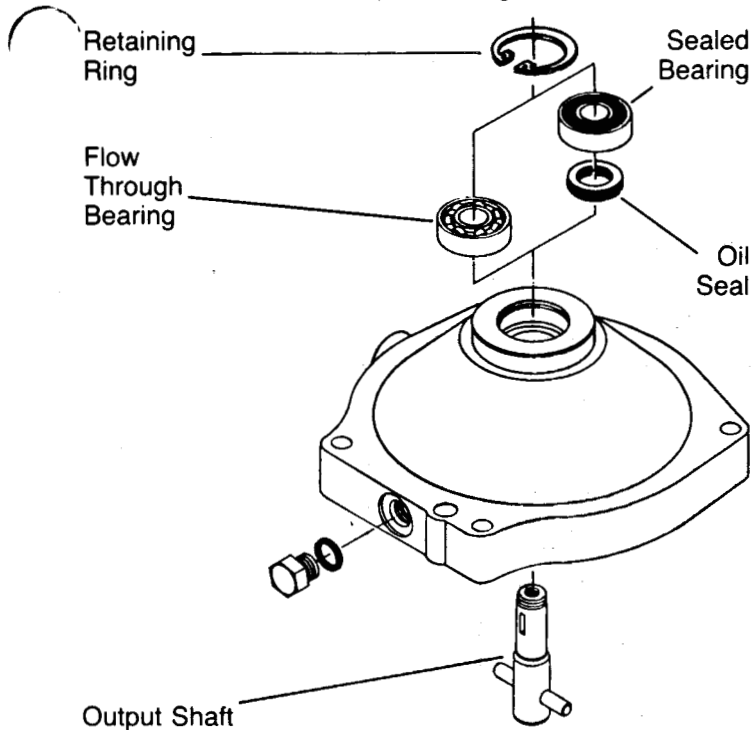

Fig. 58

107 When applicable, install oil seal in body with the rubber lip toward the counter bore in the body. Press or tap the seal into the bottom position in the counter bore.

Important: Do not over press or drive the oil seal. This may damage the rubber sealing portion of the oil seal.

108 Install output bearing. Position bearing on the body and press on the outer bearing race to the bottom position in the body.

109 Install the bearing retaining ring.

110 Install output shaft. This is a press fit. Be sure to support the inner race of the ball bearing while pressing the shaft into the bearing.

Body/Cover—Reassembly

111 Install body. Align the output shaft with the bearing located in pintle and shaft cross pin with the slot in the motor rotor assembly. Install two $\frac{5}{16}$ " x $\frac{1}{4}$ " socket head cap screws. Torque to 15 foot pounds.

Important: Be sure the output shaft rotates freely by hand. If it does not, recheck body installation.

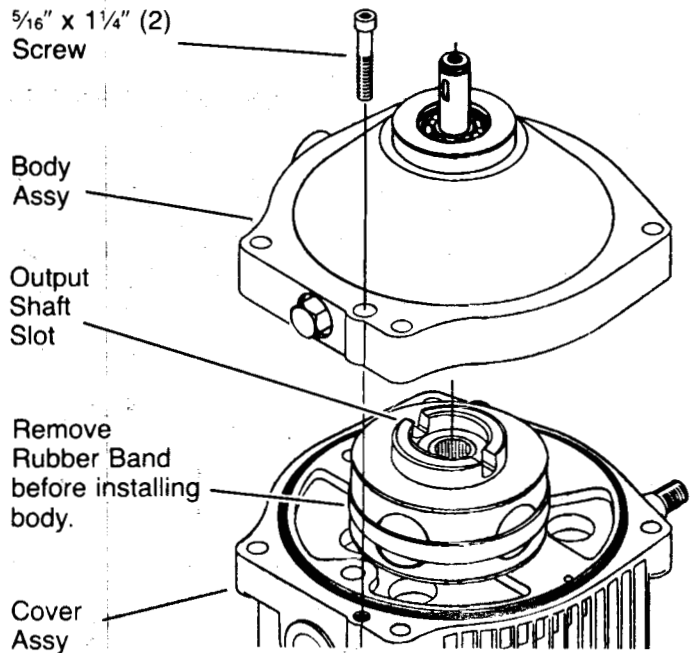

Fig. 59

Start-up Procedure

112 Fill transmission with fluid. See page 24 for fluid recommendations. On transmission that incorporates flow through output bearing, fill through the axle to the manufacturer's specified fluid level.

On transmissions that incorporate sealed output shaft bearings, fill through the reservoir to the manufacturer's specified fluid level. Start the engine and run the transmission in both directions at low engine speed for a short time to purge trapped air from the system. **Stop**, shut off engine and recheck fluid level.

The transmission is now ready for use.

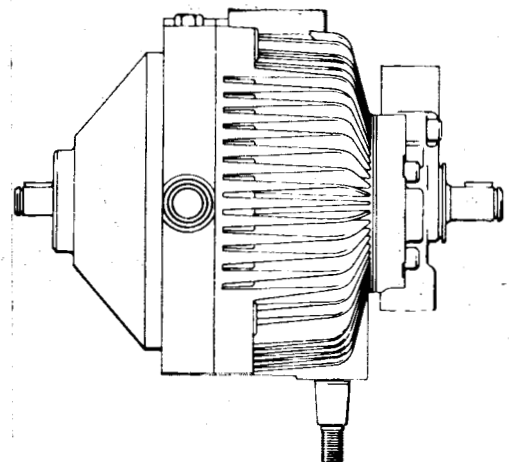

Trouble Shooting Instructions

This fault-logic troubleshooting section is designed as a diagnostic aid in locating transmission problems.

Match the transmission problem with the problem statements and follow the action steps shown in the diagrams. This will give the user expedient aids in correcting the problem and eliminating unnecessary machine down time.

System Jerky/Noisy when Starting

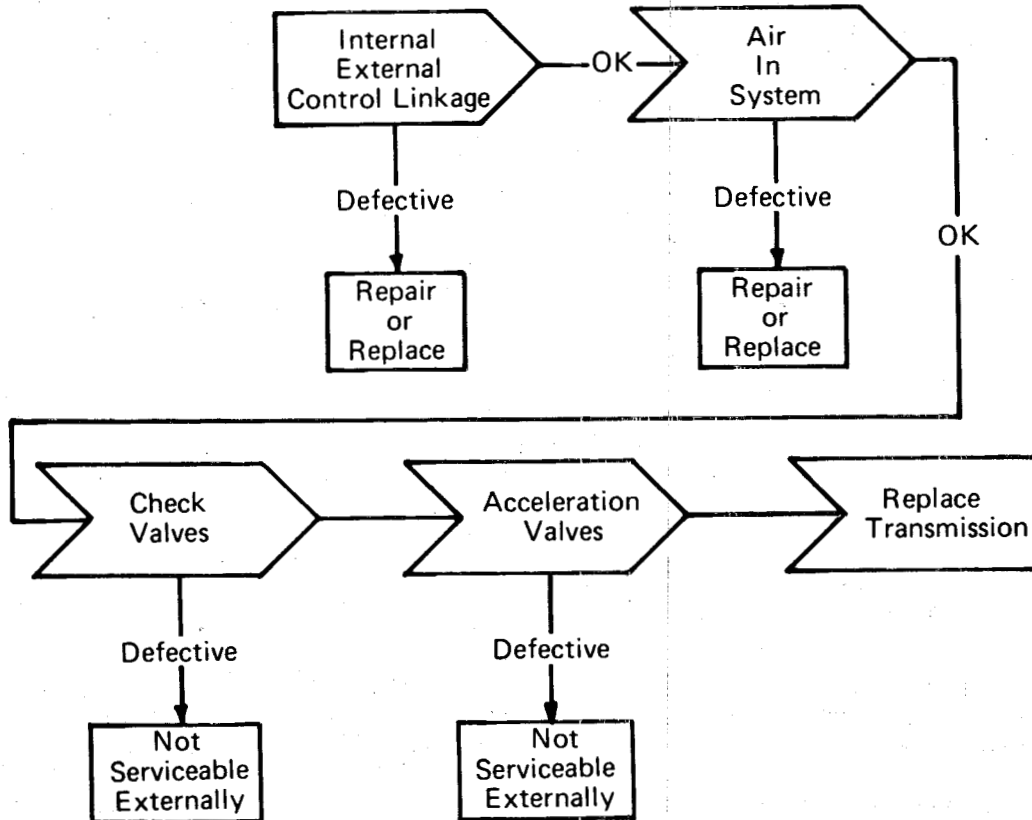

22

System Operates in One Direction Only

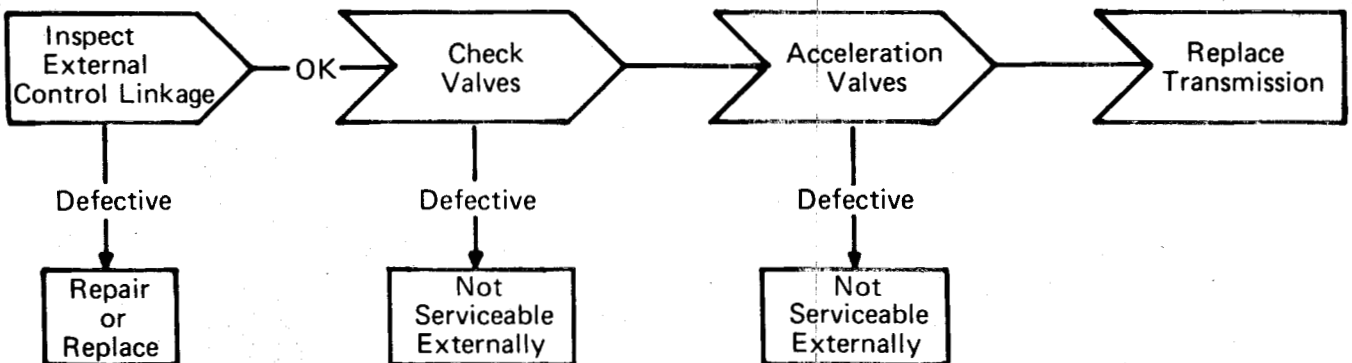

Loss of Power or System Will Not Operate in Either Direction

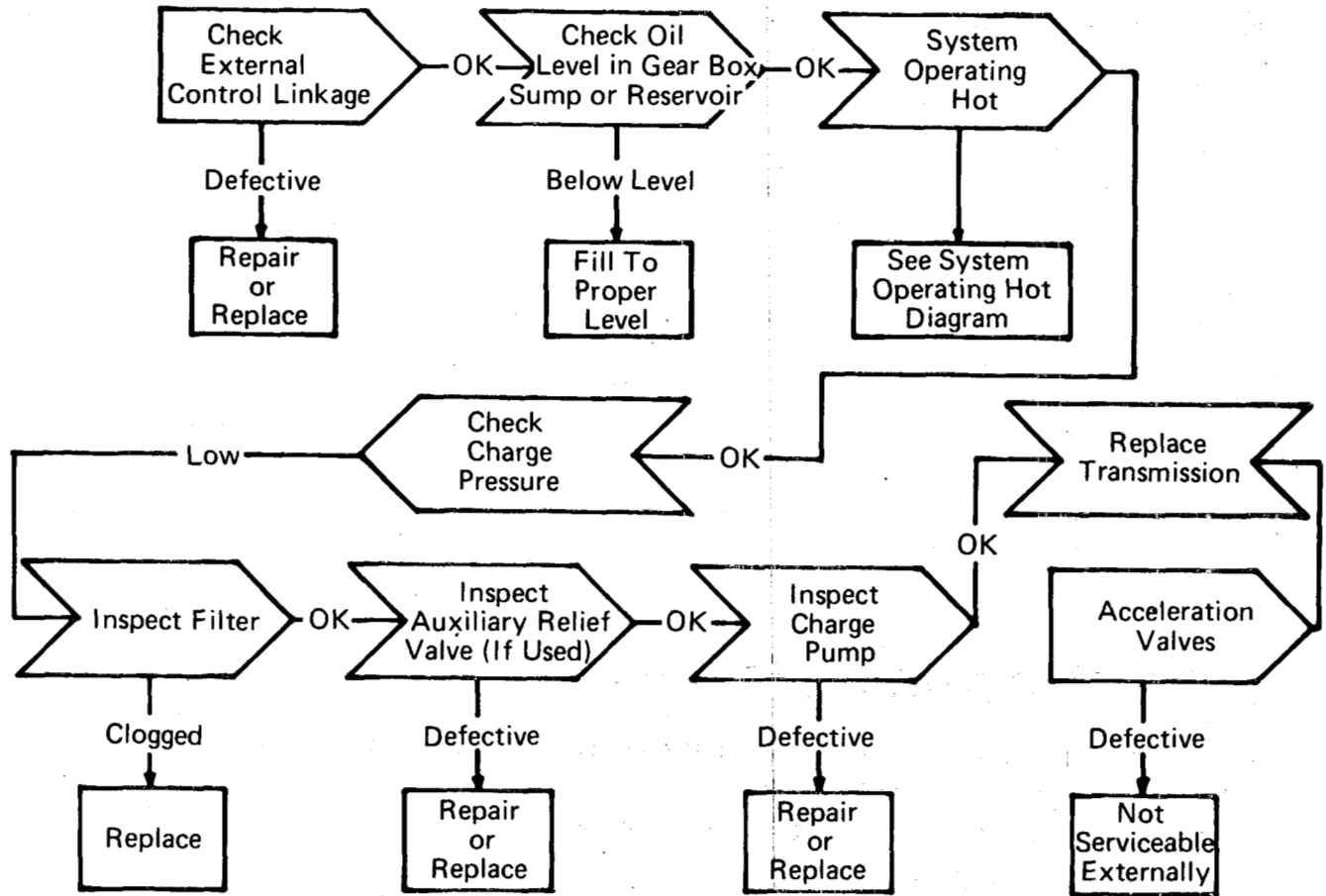

System Operating Hot

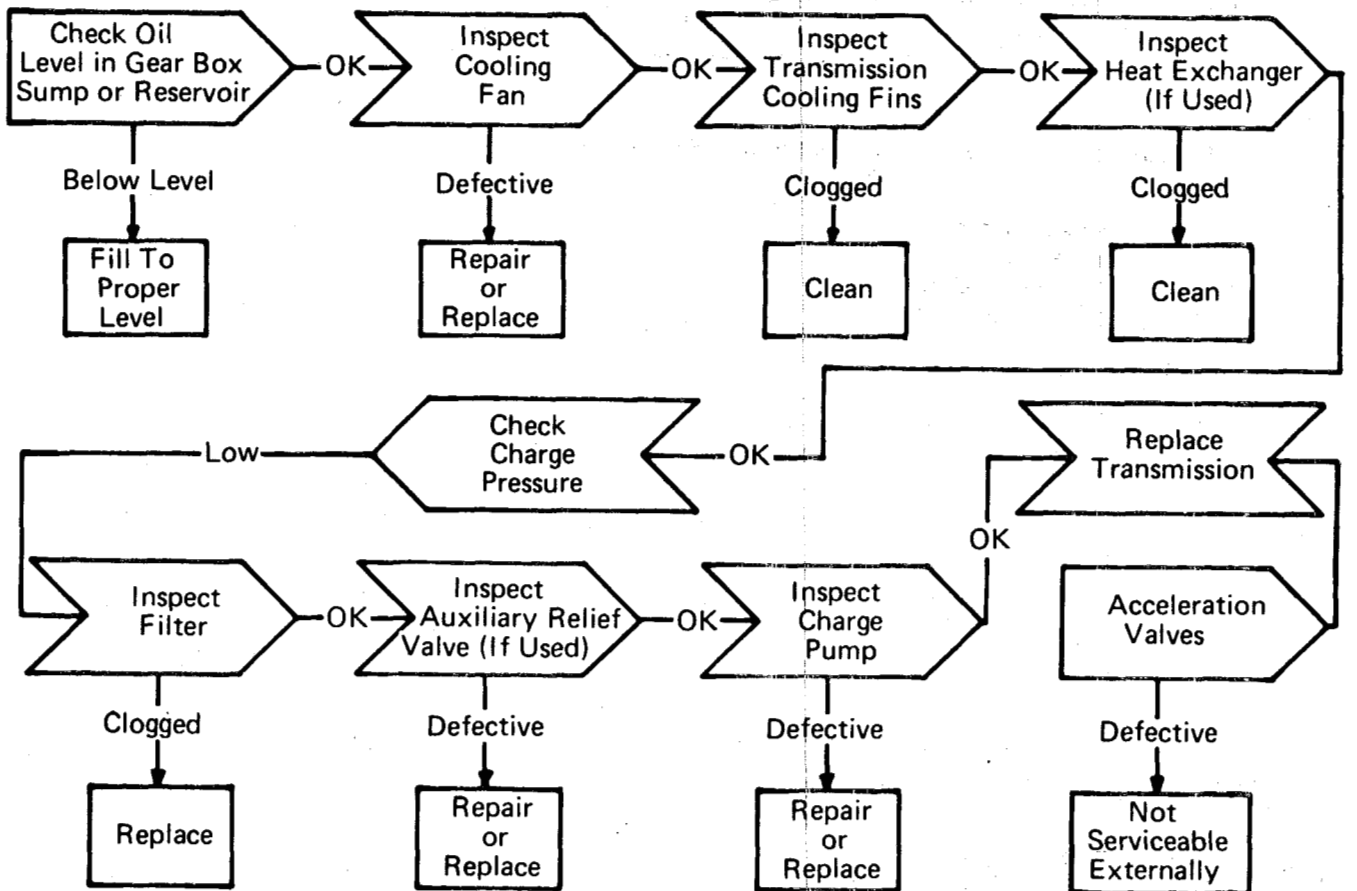

Fluid Recommendations

A reputable supplier can help you make the best selection of hydraulic fluid for use in Eaton light duty hydrostatic transmissions.

For satisfactory operation, the following fluid conditions apply:

1. Accurate level readings can be checked only when the fluid is cold.
2. If the natural color of the fluid has become black or milky, it is possible that an overheating or water contaminant problem exists.
3. Proper viscosity is essential. At normal operating temperatures, the optimum range is between 80-180 SUS (16-40 cSt), and it should never fall below 60 SUS (10 cSt).
4. The fluid should be chemically stable, incorporating rust and oxidation inhibitors.

Specific types of fluid meeting these requirements may be:

- (1) Premium hydraulic oil
- (2) Engine crankcase oil
- (3) Automatic transmission oil
- (4) Hydraulic transmission oil